



ROTAREX
FIRETEC



LPS 1223: Issue 2.3
Cert. No. 724b



COMPLETE SYSTEMS FOR COMMERCIAL KITCHENS

A COMPLETE DETECTION & SUPPRESSION SYSTEM PRE-ENGINEERED FOR COMMERCIAL KITCHENS

- ★ Easy / Flexible installation
- ★ Quick & Effective suppression
- ★ Highly Dependable: no electricity or moving parts
- ★ Highly economical



LPS 1223: Issue 2.3
Cert. No. 724b

LPCB Certified and Listed for Fixed Fire Extinguishing Systems for Catering Equipment. Tested for quality, Safety and Performance according to LPS 1223, Issue 2.3.



EVERYTHING YOU NEED TOGETHER IN ONE BOX



REDUCES EVEN THE MOST CRITICAL KITCHEN FIRE RISKS:

- Flammable grease and open flame in cooking areas
- Human injury
- Damage to cooking equipment and peripheral kitchen area
- Work stoppage
- Loss of client goodwill

THE FIREDETEC® DIFFERENCE

Rotarex FireDETEC® systems use a proprietary continuous linear sensor tube that reliably detects and actuates release of the extinguishing agent using pneumatic technology. It is more flexible, space efficient and cost effective versus alternative mechanical or electronic systems.

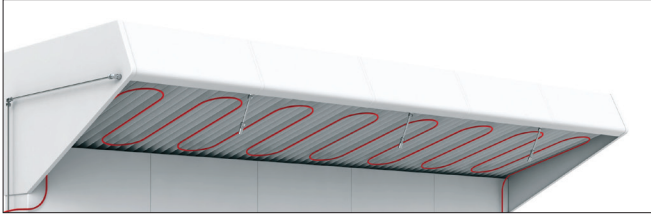

1. Quick & Easy installation directly above high-risk cooking areas:
 The flexible sensor tubing is easily installed directly inside the extractor hood - directly above cooking areas.

When in service, the tubing is pressurized with dry nitrogen to 16 bar. The dynamics of pressurization make the tubing more reactive to heat.

2. Early fire detection:
 If a flame-up occurs, the heat of the fire causes the pressurized sensor tube to burst at the hottest spot (approx. 175°C)

3. Instant suppression:
 The sudden tube depressurization actuates the special pressure differential valve and instantly floods the cooking area with Class F extinguishing agent. The fire is quickly suppressed just moments after it began... minimizing damage and downtime.

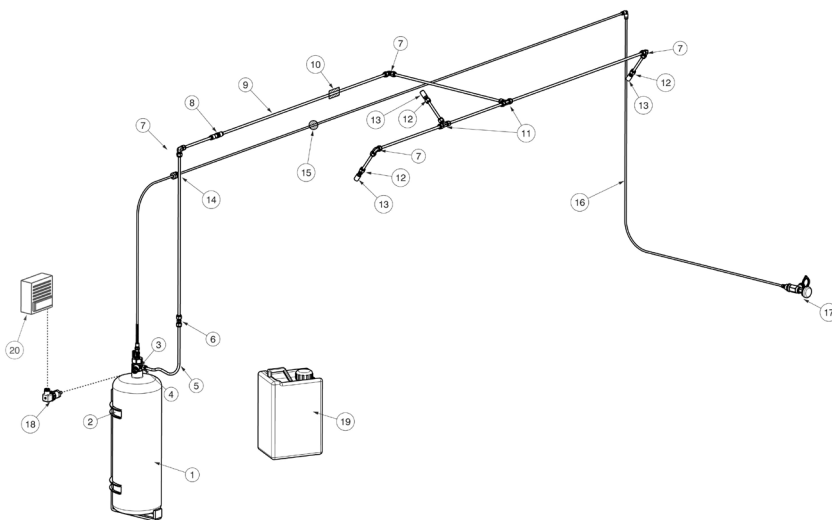

Pos.	Qty.	Description
1	1	ILP cylinder / valve assembly 9 Liter (not filled)
2	1	Cylinder bracket
3	1	Gasket
4	1	Tube fitting (nickel plated)
5	1	Steel hose
6	1	Tube fitting - straight union
7	4	Tube fitting - Elbow
8	1	Cross panel-fitting
9	6	Stainless steel tubing (1m)
10	4	Pipe bracket (Ø8mm)
11	2	Tube fitting - Tee
12	3	Tube fitting - straight G ¼"
13	3	Nozzle
14	1	Cross panel-fitting
15	20	Screw clips for tube attachment
16	1	FireDETEC Tube grey (10m)
17	1	Manuel release device
18	1	Pressure switch
19	1	FireDETEC® suppression agent (9 liter canister)
OPTIONAL		
20	1	Alarm box

SPECIFICATIONS

Extinguishing agents	Class F	Tube pressure	16 bar	Working temperature	-20°C to +60°C
Propellant	Nitrogen	Sensor tube burst temperature	175°C	Cylinder volume	12 liters
Volume of Extinguishing agent	9 liters	Cylinder pressure	16 bar	Weight (filled)	13 Kg

WORLDWIDE HEADQUARTERS

24, rue de Diekirch, BP 19
L-7505 Lintgen
Luxembourg
Tel.: +352 32 78 32-1
Fax: +352 32 78 32-854
E-mail: info@firetec.rotarex.com

OTHER AVAILABLE PRE-ENGINEERED SYSTEMS:

ELECTRICAL CABINETS



CNC MACHINES



FUME CABINETS



VEHICLE ENGINES

